



Packing Procedure For 8x13 96B FBGA Product (t=1.0mm)

Table of Contents

(1) PACKING PROCEDURE	2
(2) PACKAGING QUANTITY.....	4
(3) SPECIFICATION OF SHIPPING BOX	5
(4) PACKING DRAWING.....	10

(1) Packing Procedure -1

■ Packing procedure for Tray

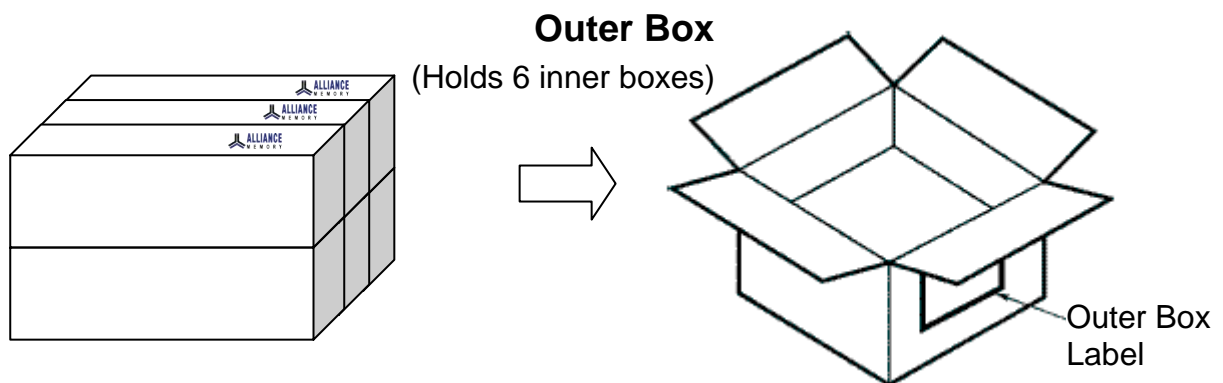
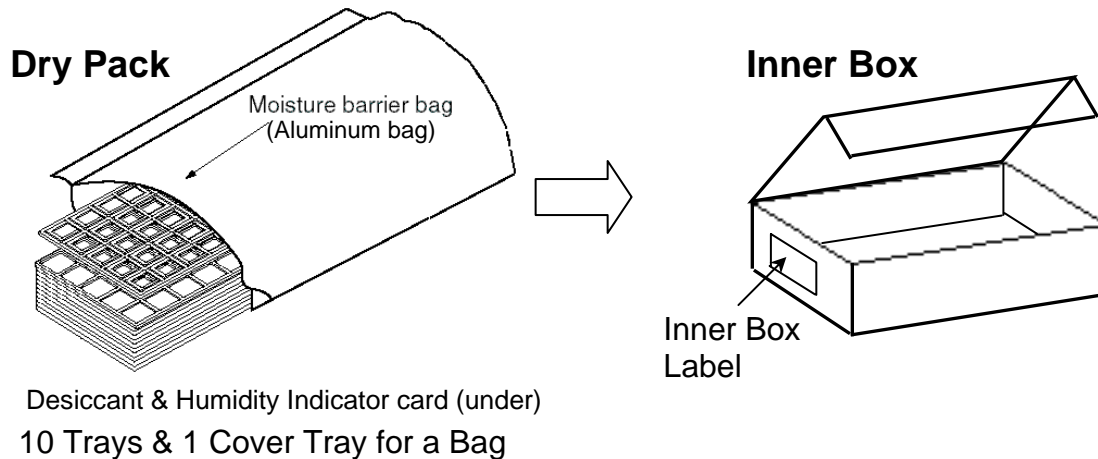
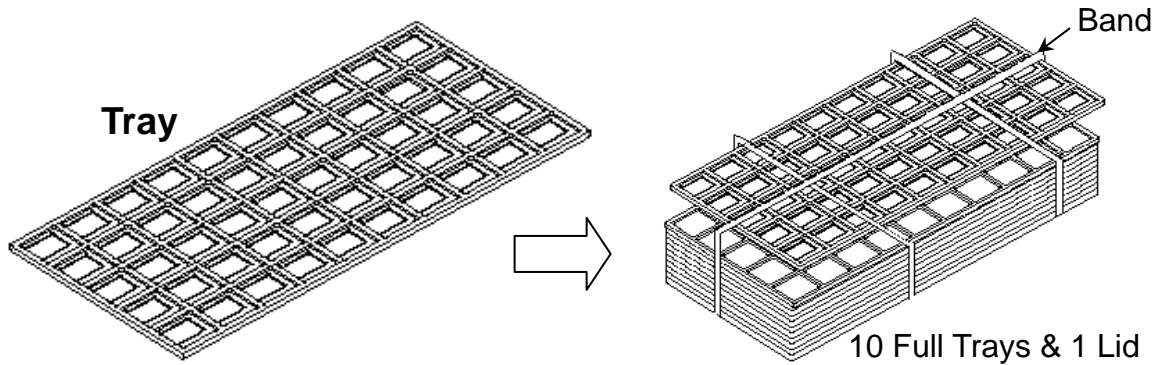

(1) Packing Procedure -2

■ Packing procedure for Tape & Reel

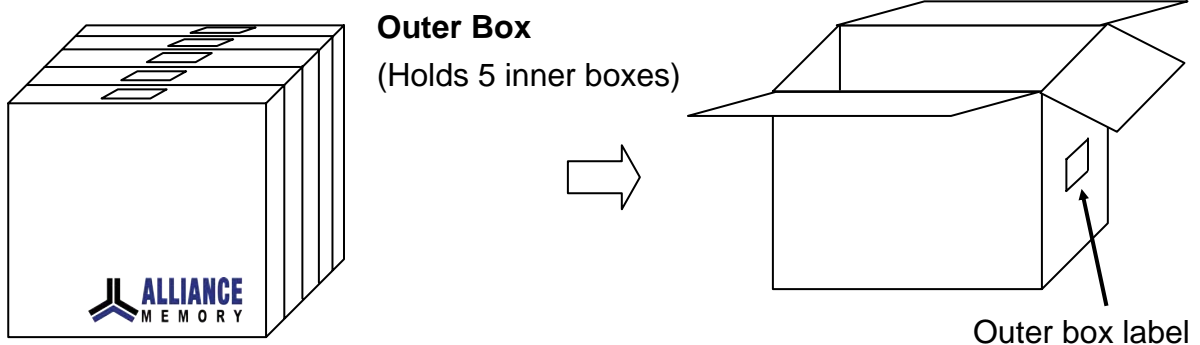
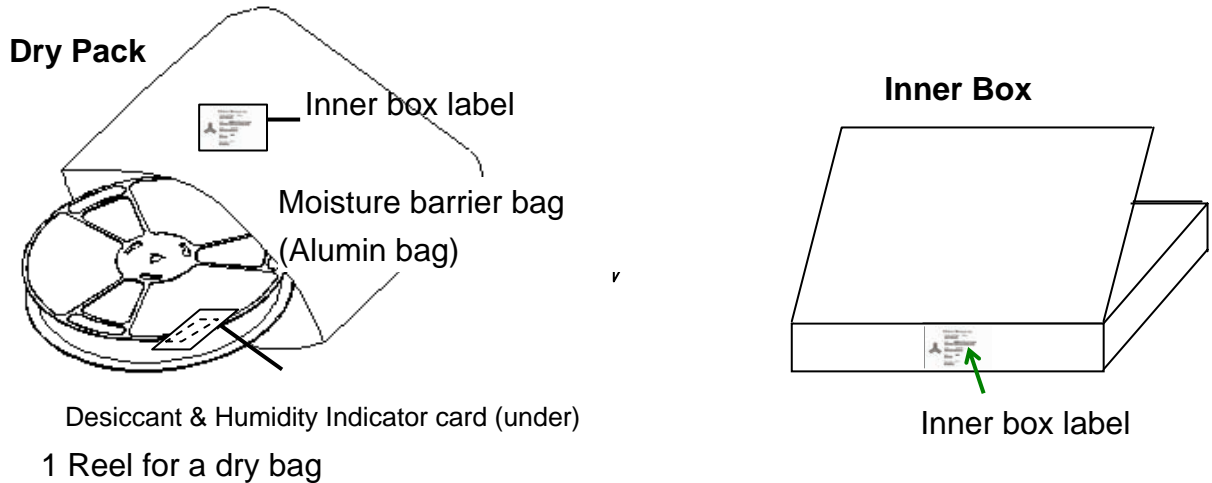
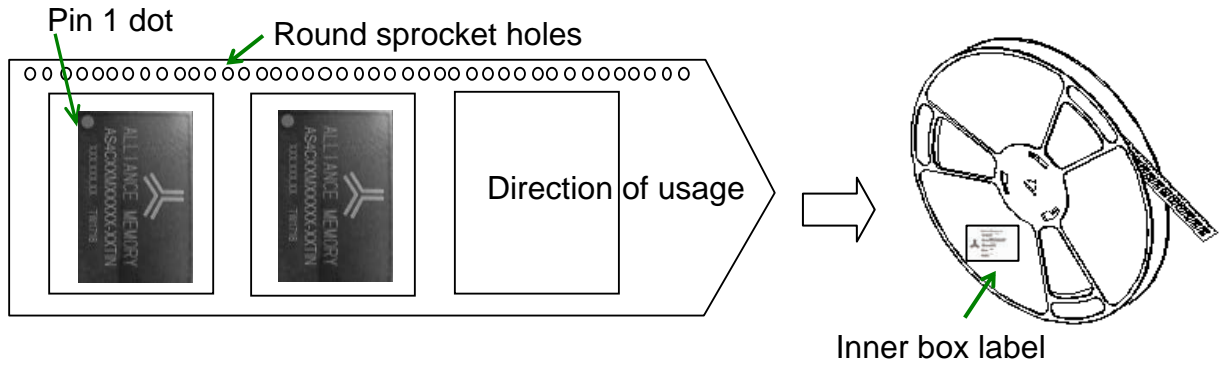

(2) Packaging Quantity

■ Quantity of Container

The quantity for each container is described as below table for reference.

Pkg. Type	Packing Qty	Dry Bag	Inner Box	Outer Box
8*13 t=1.0 96 Ball- WBGA	209 ea/Tray	10 Tray (2090 ea)	1 Dry Bag (2090 ea)	6 Inner Boxes (12540 ea)
	1500 ea/T&R	1 Reel (1500 ea)	1 Dry Bag (1500 ea)	5 Inner Boxes (7500 ea)

(3) Specification of Shipping Box -1

■ Tray Outer Box Drawing

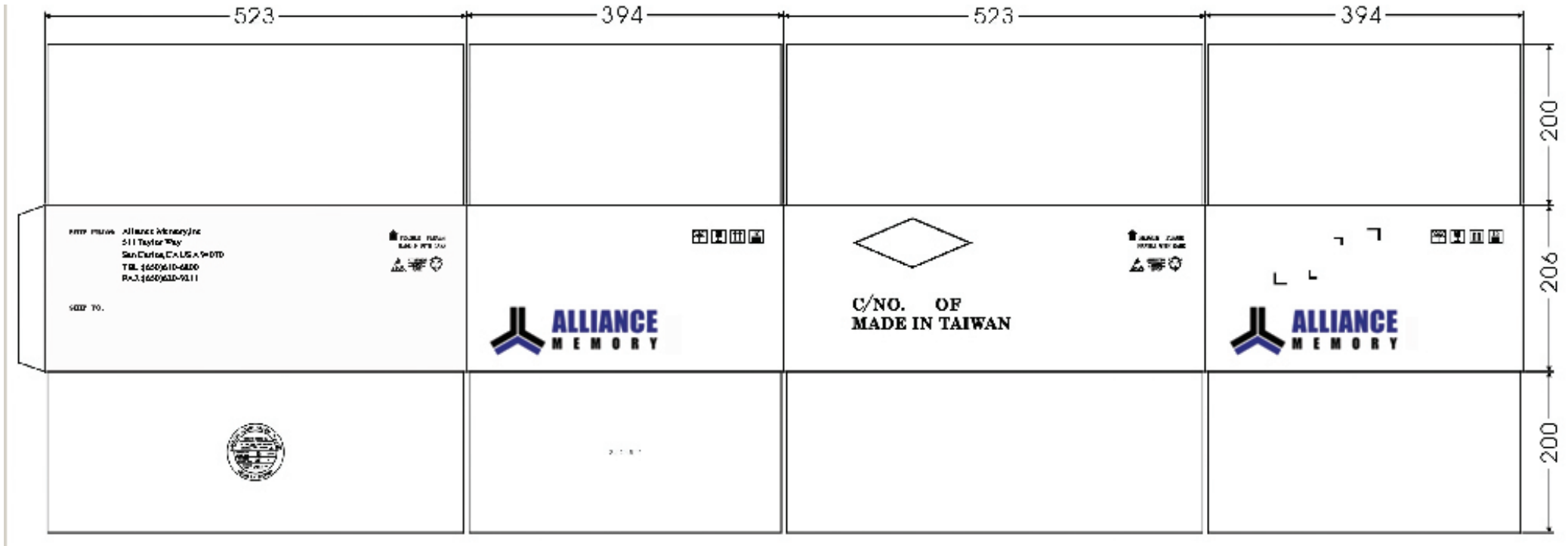

Tolerance: ± 5mm

(3) Specification of Shipping Box -2

■ Tray Outer Box Drawing-buffer

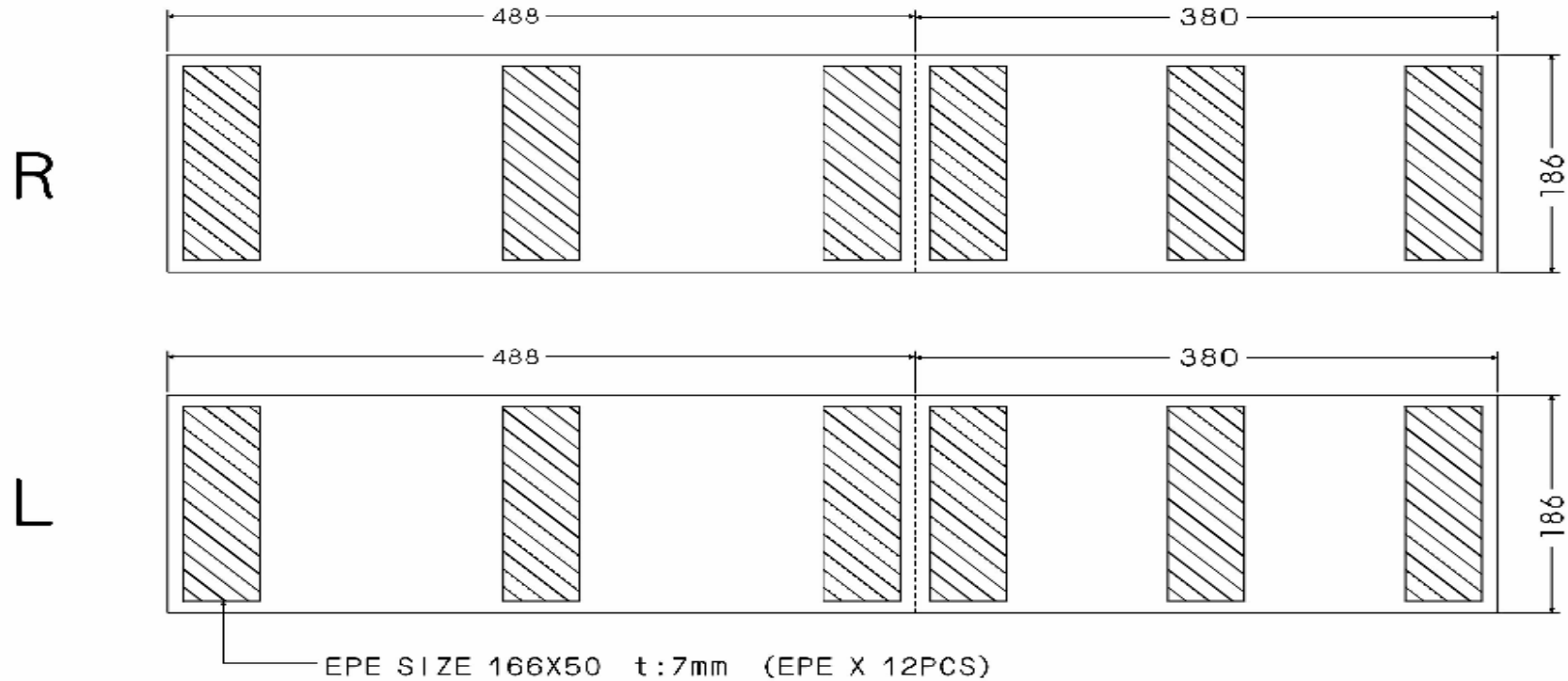

Tolerance: $\pm 3\text{mm}$

(3) Specification of Shipping Box -3

■ Tray Inner Box Drawing

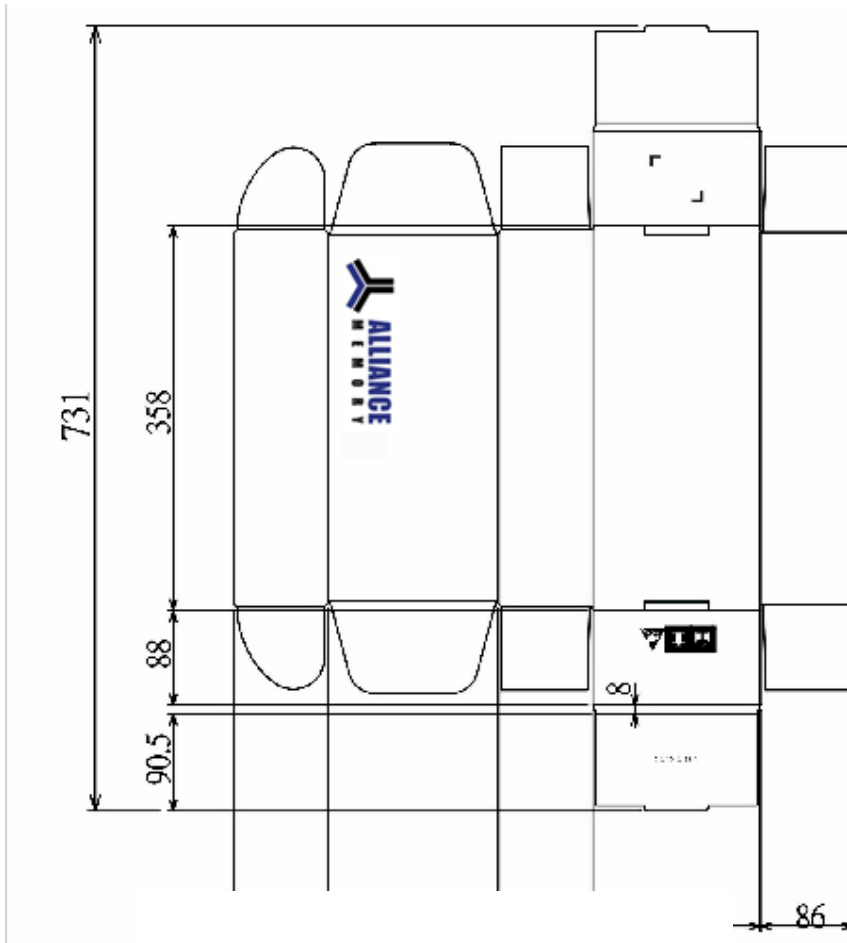

Tolerance: $\pm 3\text{mm}$



(3) Specification of Shipping Box -4

■ T/R Outer Box Drawing

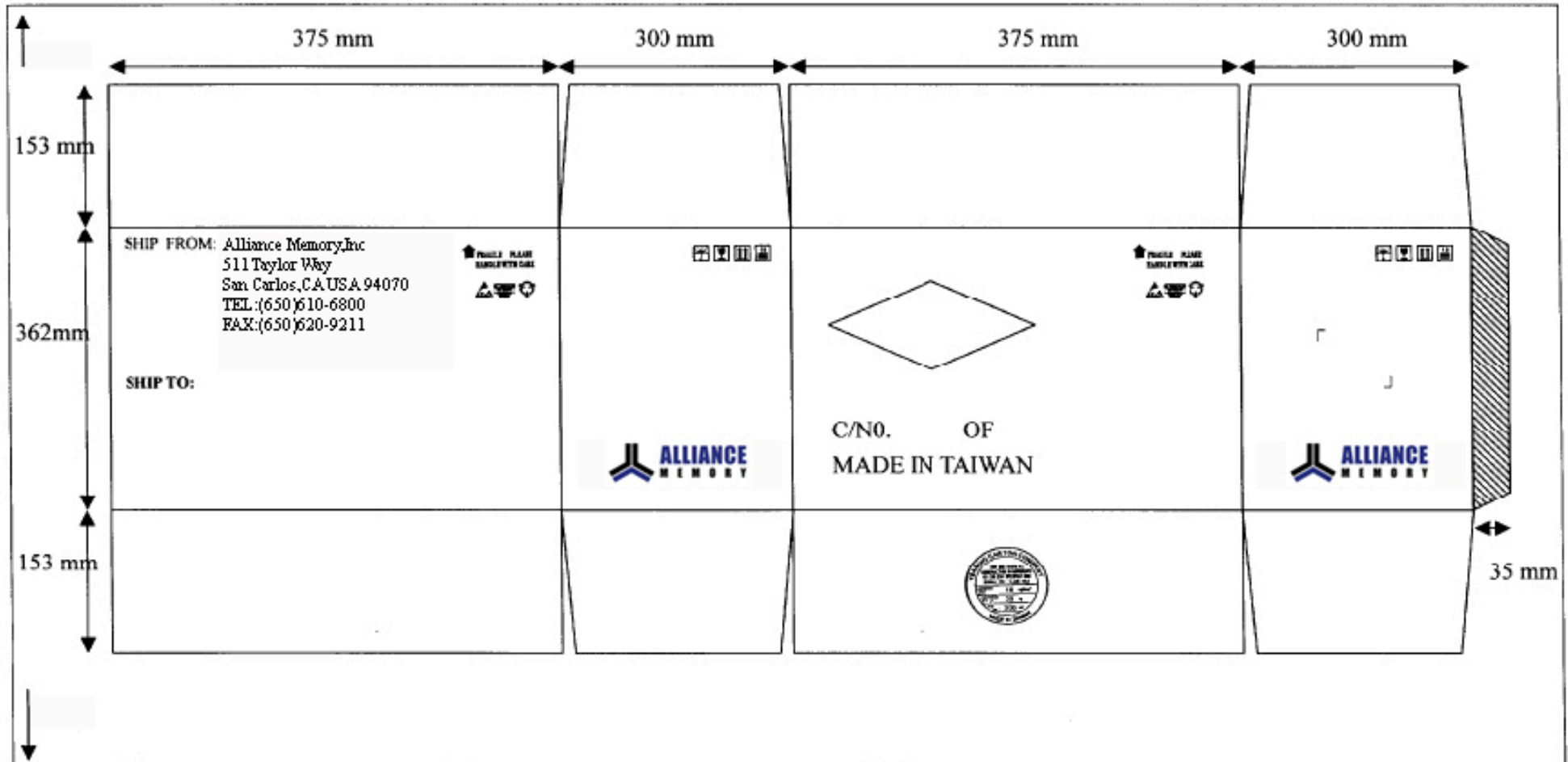

(3) Specification of Shipping Box -5

■ T/R Inner Box Drawing

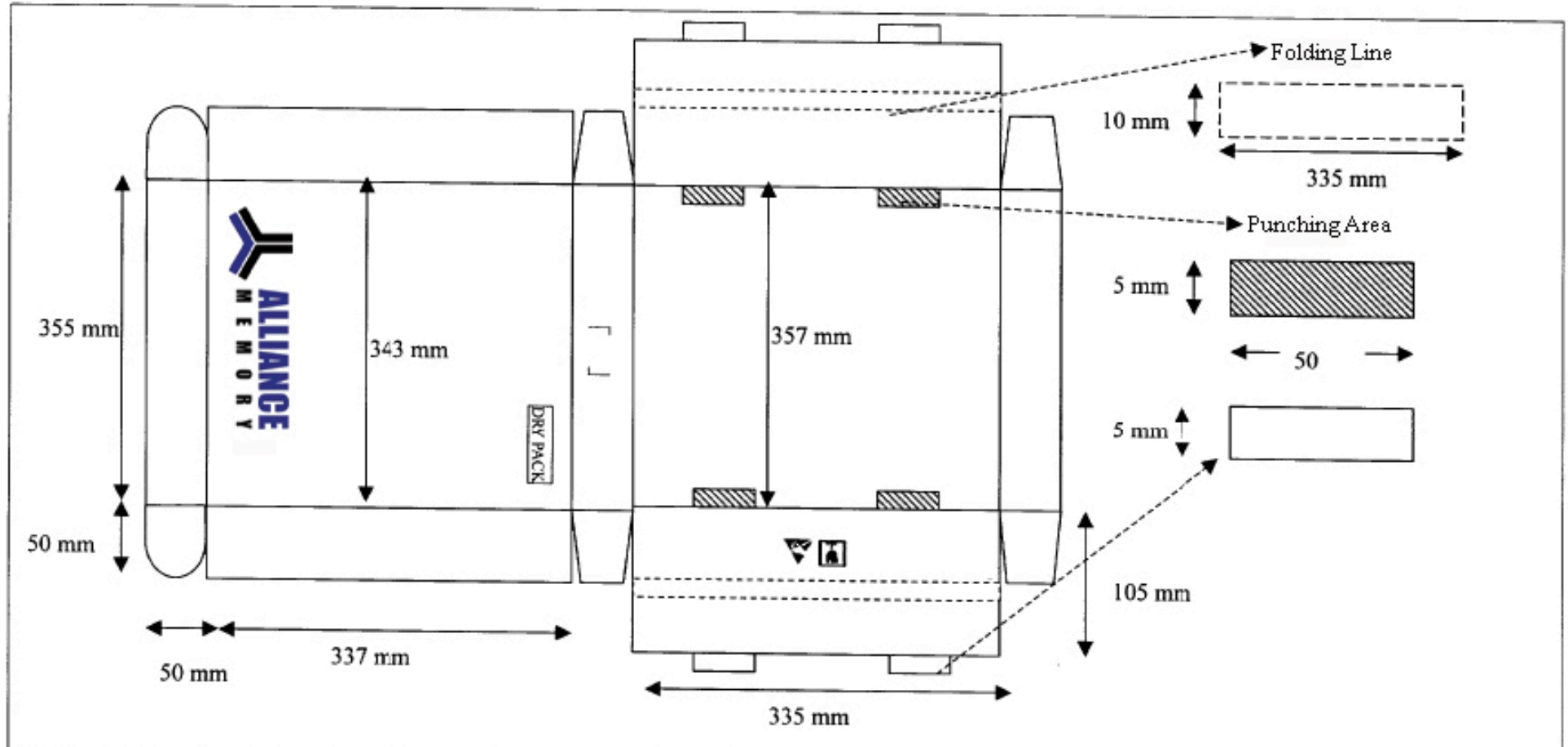

(4) Packing Drawing -1

- Tray Drawing of 8x13 96B-WBGA (t=1.0mm)

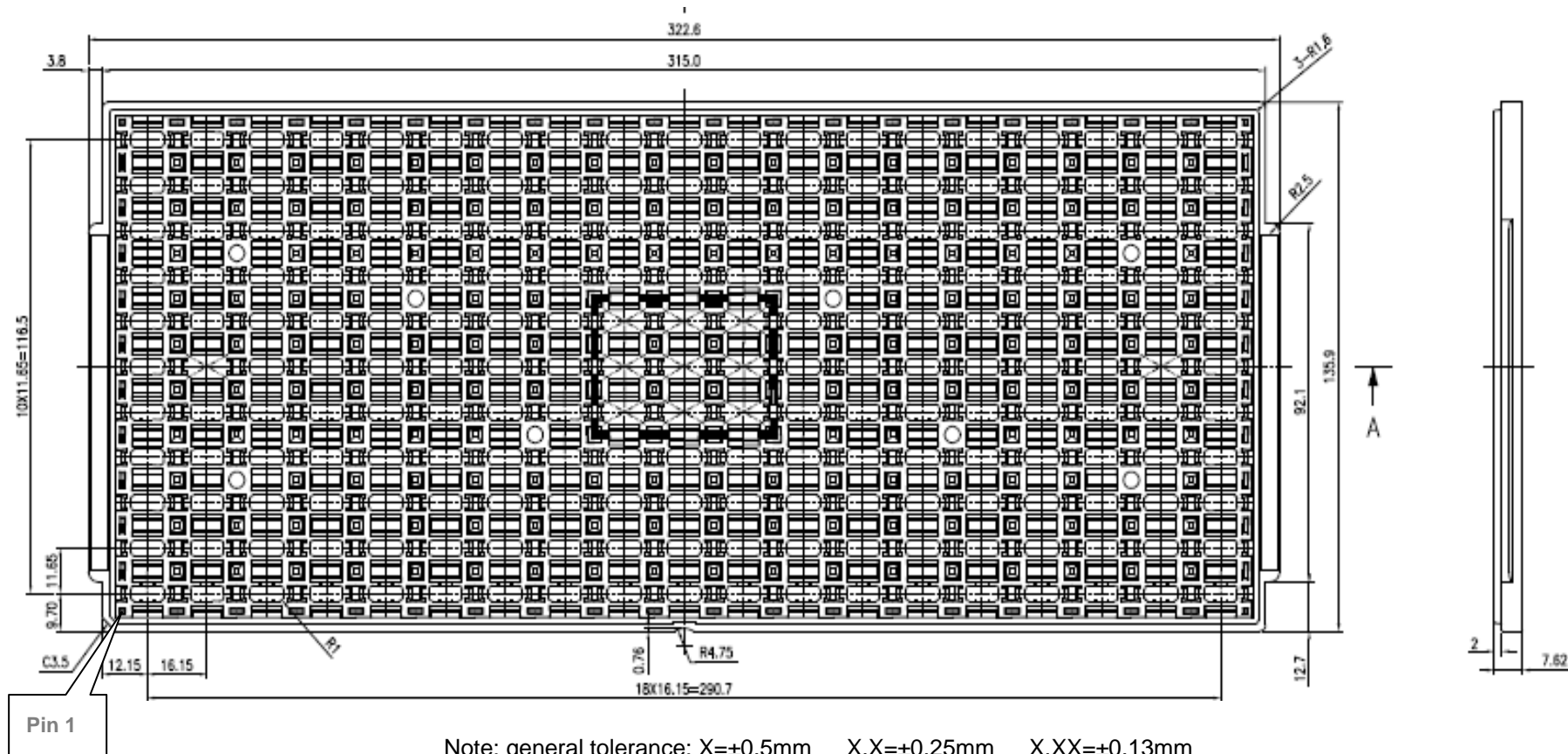

(4) Packing Drawing -2

■ Lock Reel Drawing of 8x13 96B-WBGA(t=1.0mm)

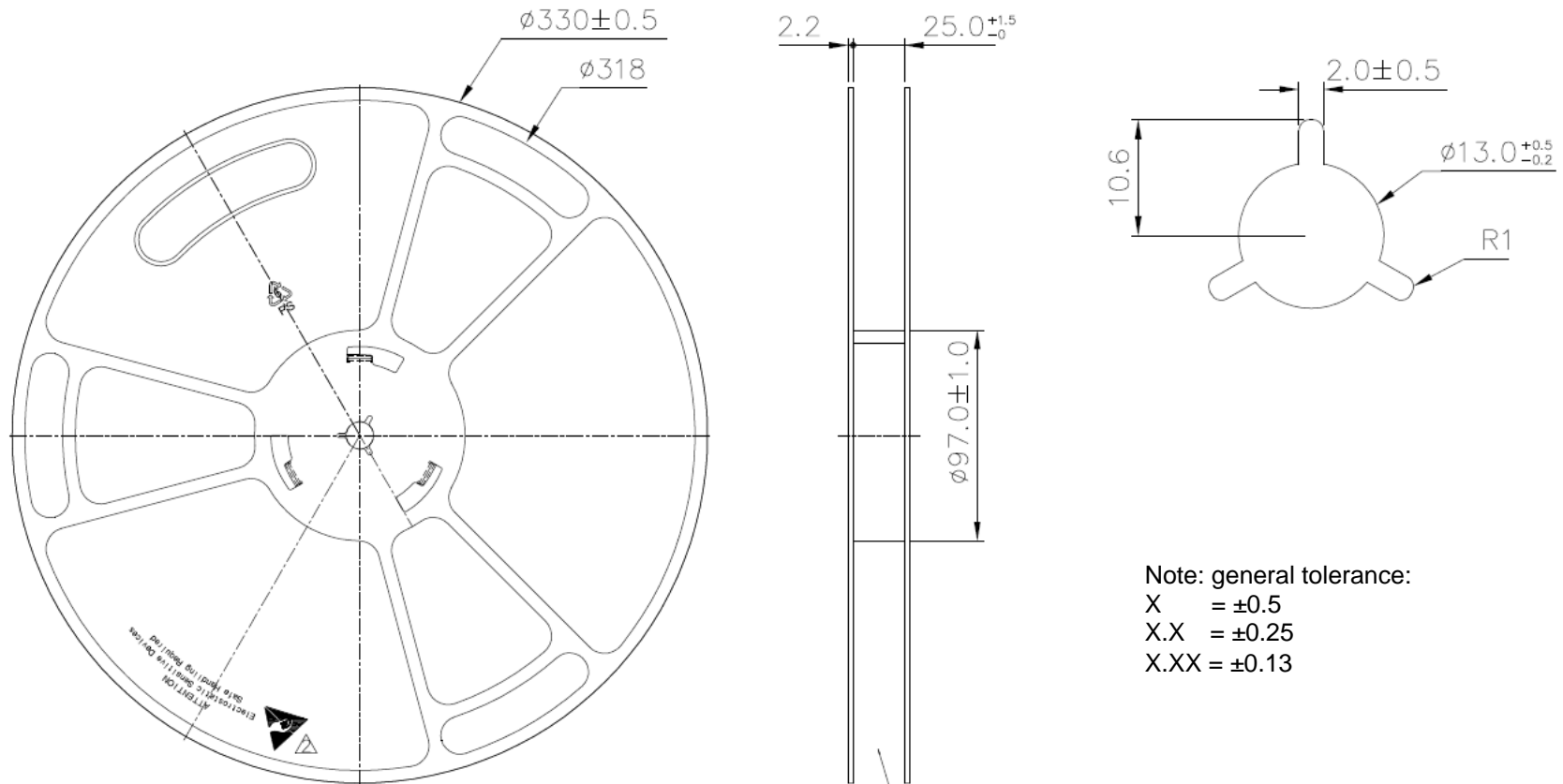

Note: general tolerance:

X = ± 0.5

X.X = ± 0.25

X.XX = ± 0.13

(4) Packing Drawing -3

- Carrier Tape Drawing of 8x13 96B-WBGA (t=1.0mm)

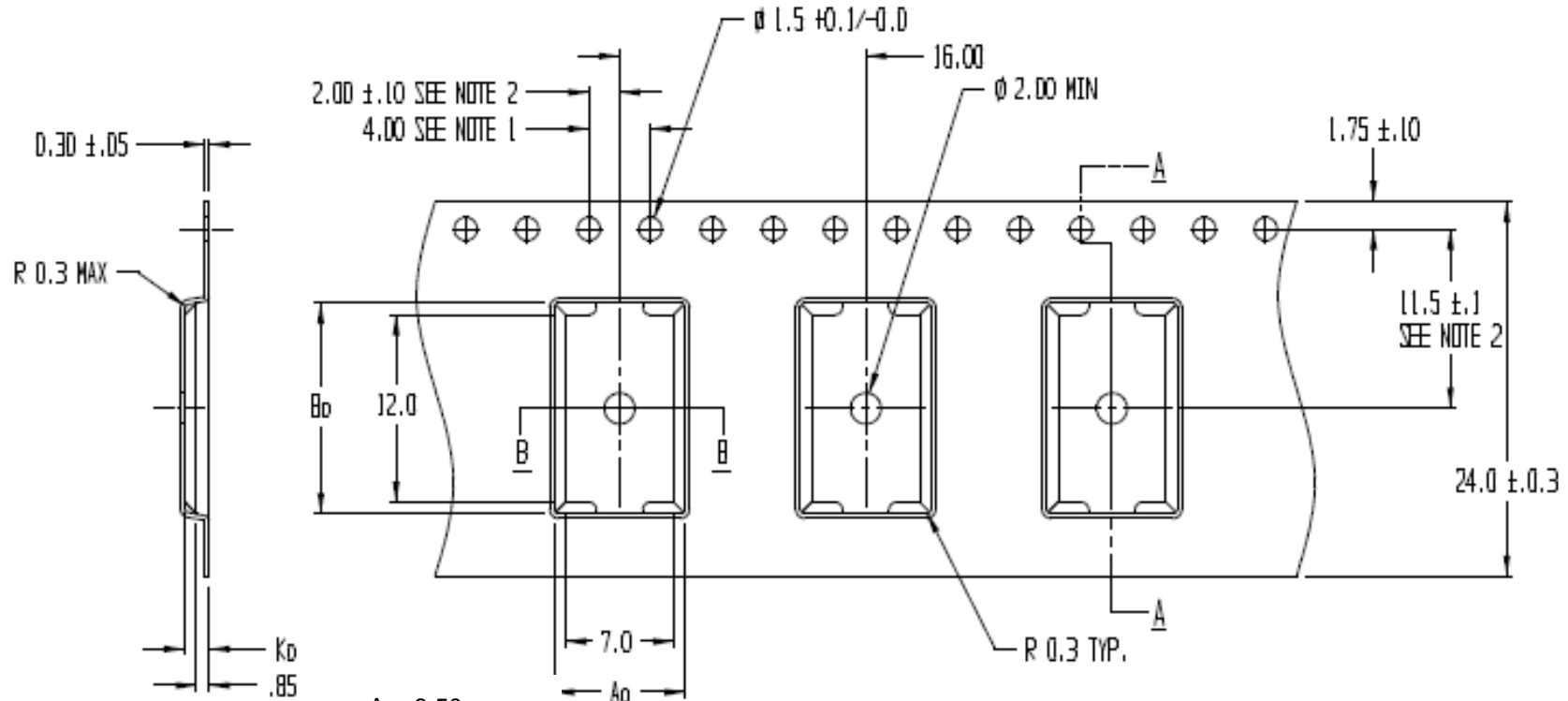

Ao=8.50

Bo=13.50

Ko=1.60

Note: general tolerance: X = ±1 X.X = ±0.25 X.XX = ±0.13