



Packing Procedure For 44L-TSOP-II Product

Table of Contents

(1) PACKING PROCEDURE	1
(2) PACKAGING QUANTITY.....	2
(3) SPECIFICATION OF SHIPPING BOX	4
(4) PACKING DRAWING	9

(1) Packing Procedure -1

1. Packing procedure for Tray (11.76x18.41mm 44L TSOP-II)

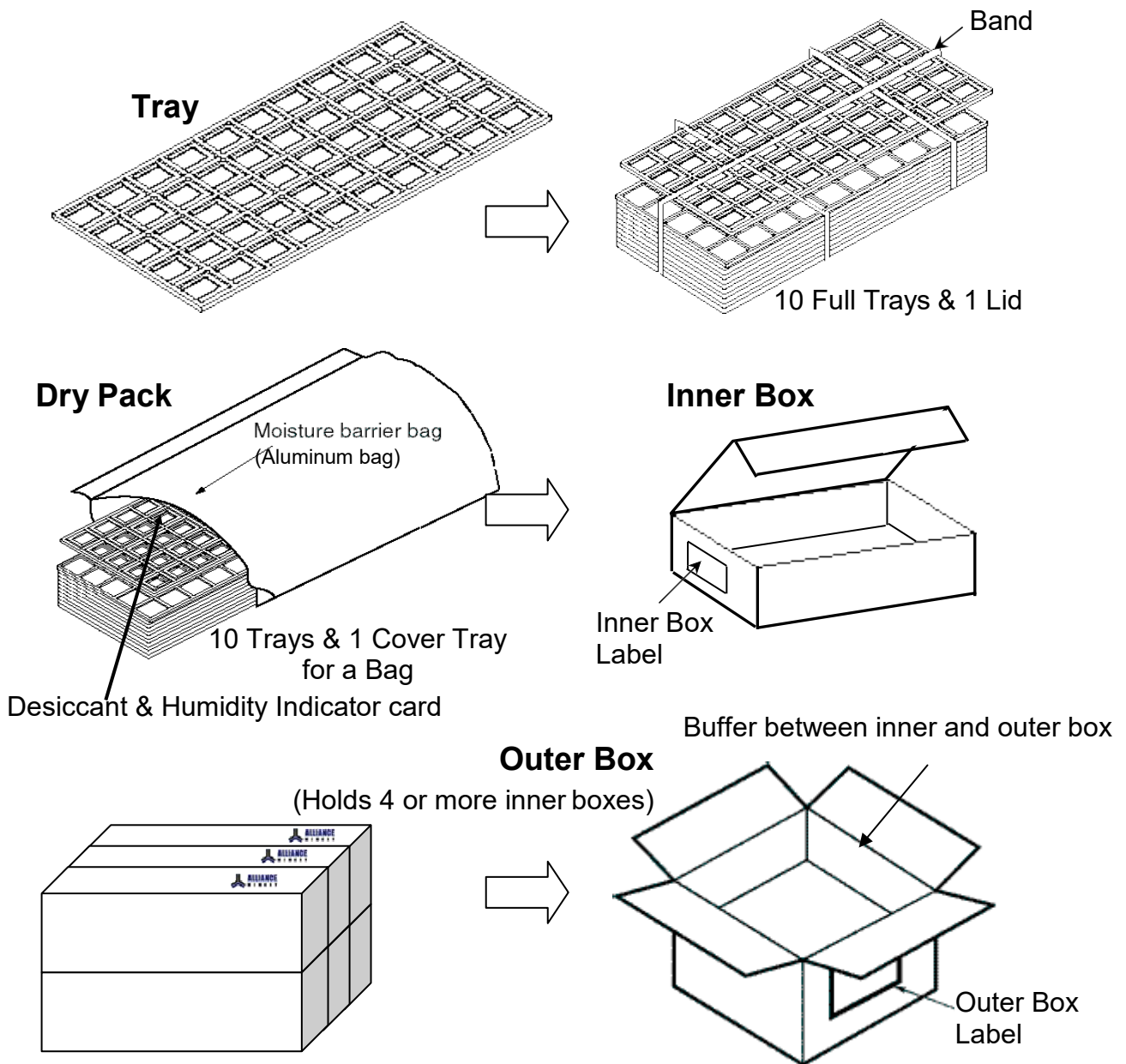

(1) Packing Procedure -2

■ Packing procedure for Tape & Reel

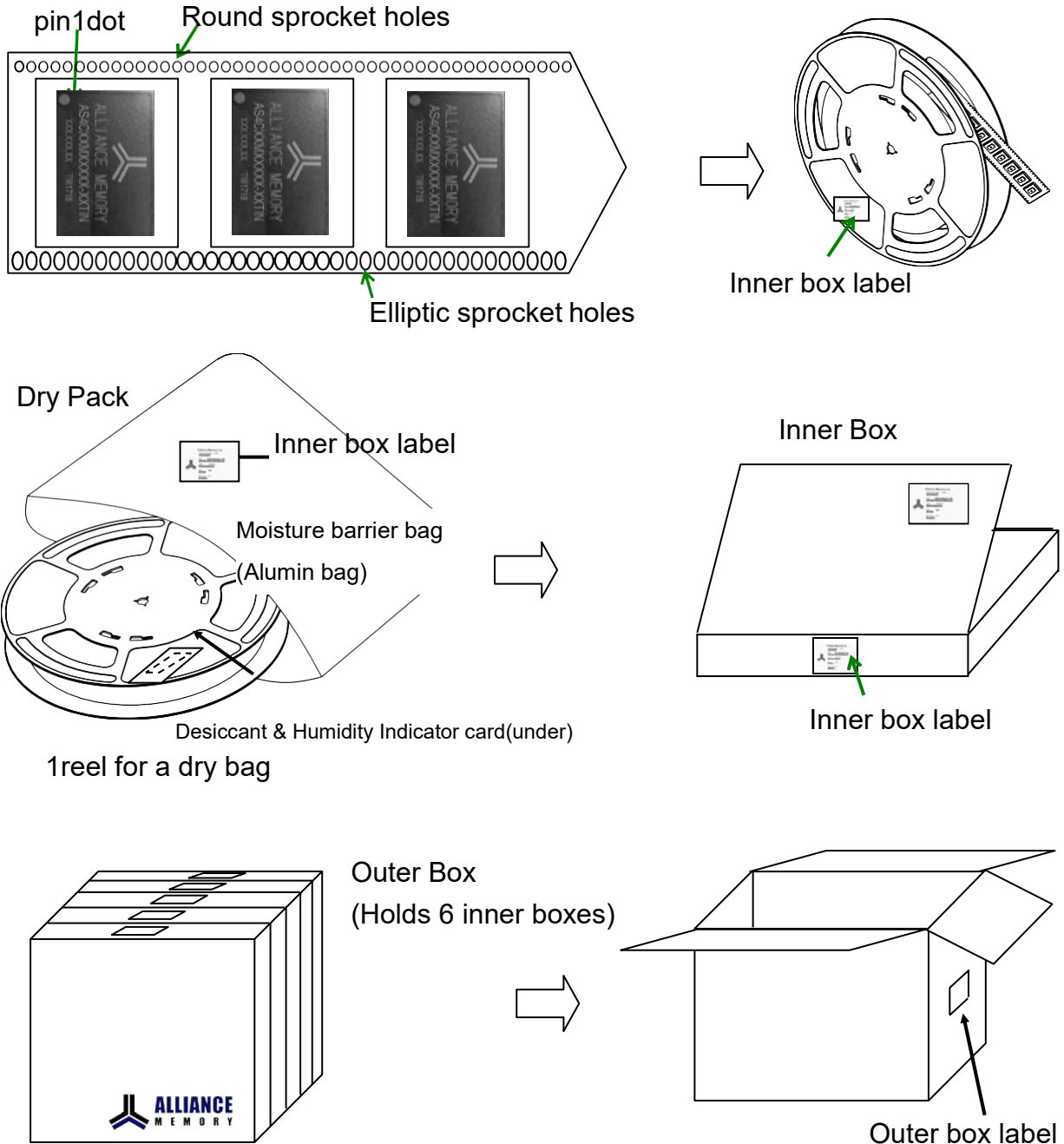

(2) Packaging Quantity

■ Quantity of Container

The quantity for each container is described as below table for reference.

▪ Tray Packing Information

Package Type	Q'ty in Tray	Tray in In-Box	Q'ty in In-Box	In-Box in Out-Box	Q'ty in Out-Box
44L TSOP-II 11.76x18.41mm	135 ea	10 ea	1,350 ea	4 ea	5,400 ea
				8 ea	10,800 ea

Tray Pocket		Tray Pocket to Pocket	
Length	Width	Y Pitch	X Pitch
11.87mm	18.88mm	13.67mm	20.42mm

▪ T/R Packing Information

Package Type	Q'ty in Reel	In-Box in Out-Box	Q'ty in Out-Box
44L TSOP-II 18.41x11.76mm	2,000 ea	6 ea	12,000 ea

Reel/Hub Diameter	Carrier Tape Width	Carrier Tape Pocket			Pocket to Pocket Pitch	Cover Tape Width
		Length	Width	Height		
13"/4"	32.00mm	12.20mm	18.90mm	1.80mm	16.00mm	25.50mm

(3) Specification of Shipping Box-1

- Tray Outer Box Information for 4 Inner Box (380 x 365 x 222)

TOP			
			
		BOTTOM	

- Tray Outer Box Information for >4 Inner Box (380 x 365 x 438)

TOP			
			
		BOTTOM	

(3) Specification of Shipping Box -2

■ Tray Inner Box Drawing (366 x 175 x 105)

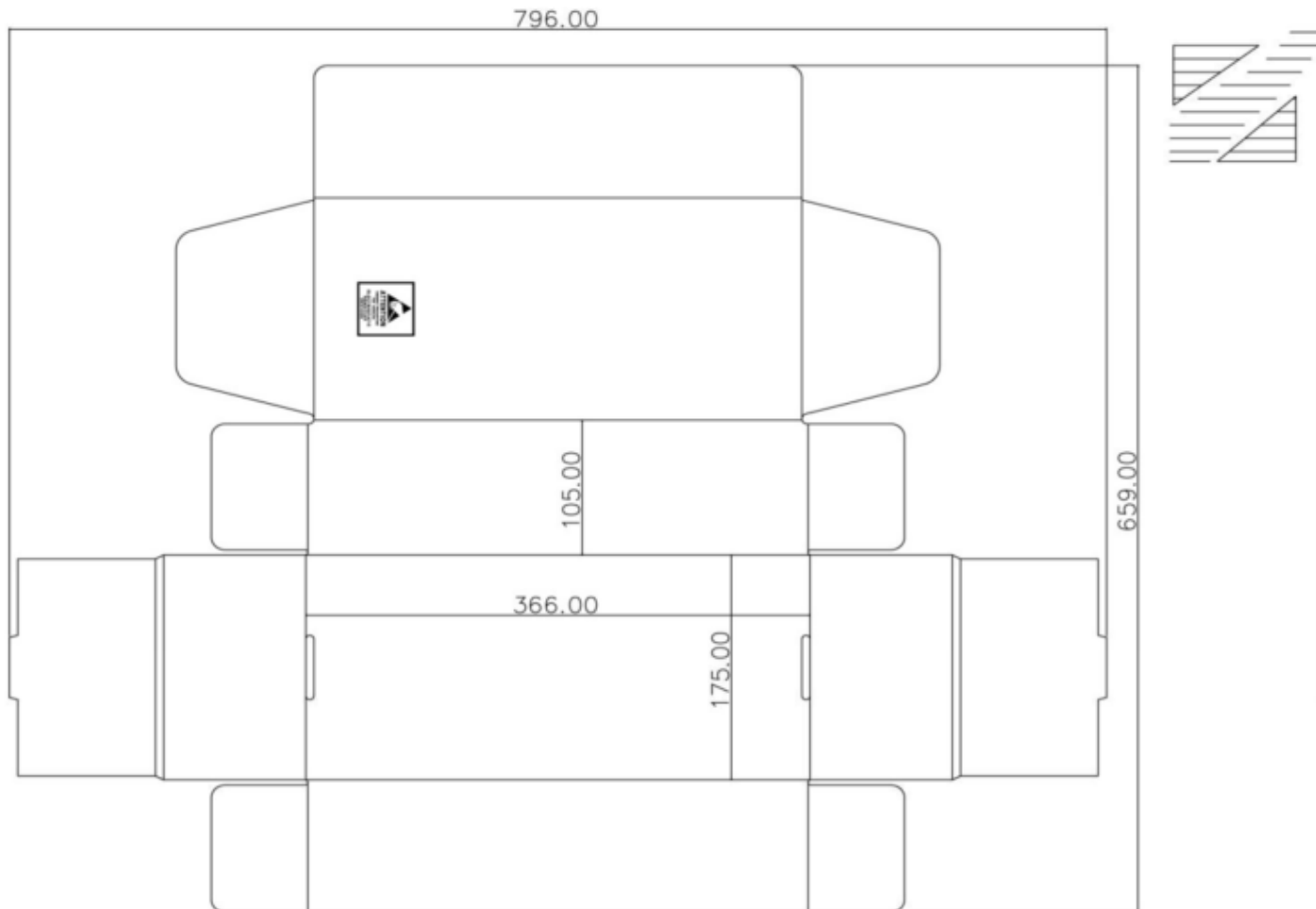

(3) Specification of Shipping Box -3

- T/R Outer Box Drawing (375 x 345 x 382)

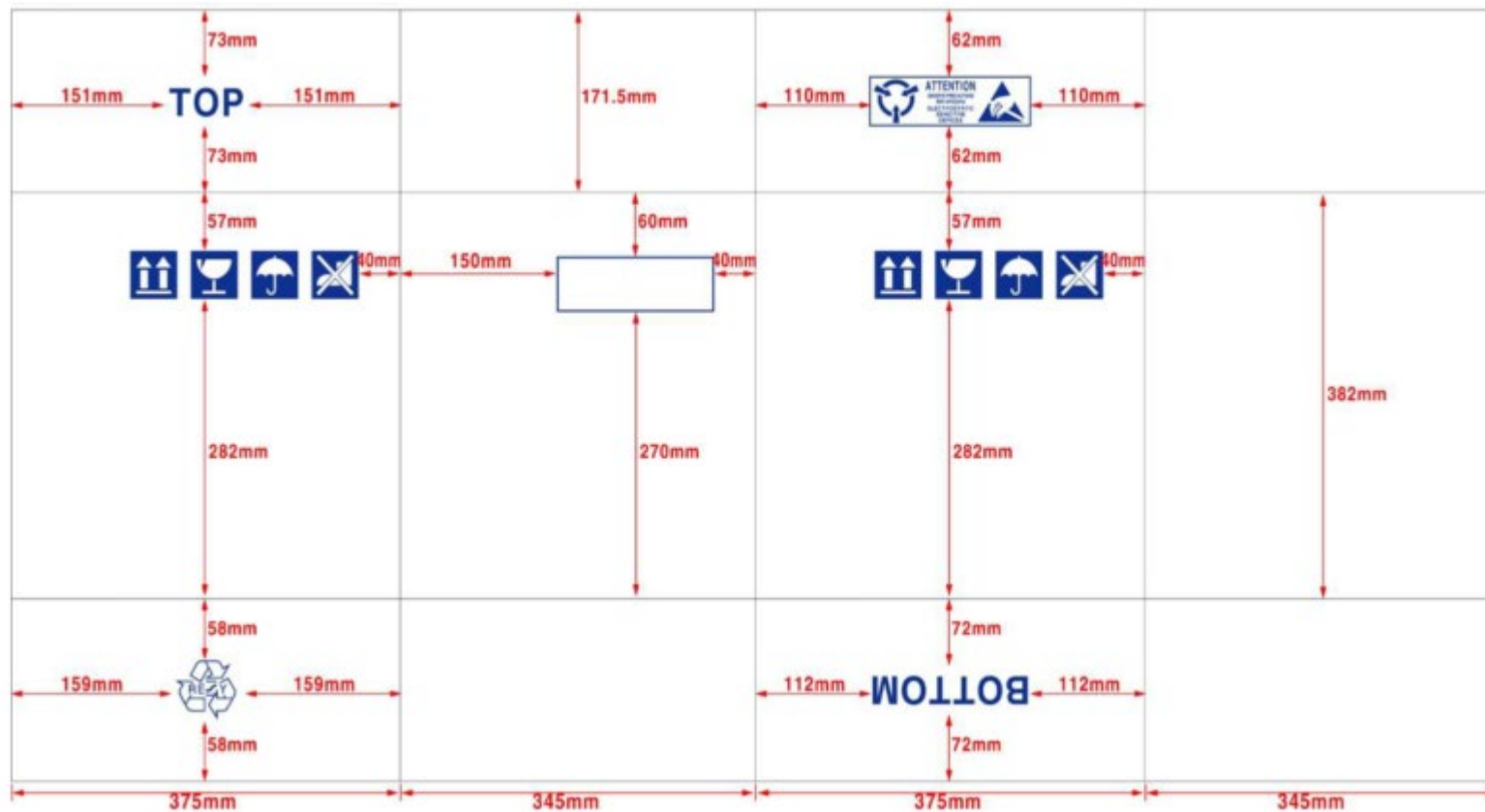

(3) Specification of Shipping Box -5

- T/R Inner Box Drawing

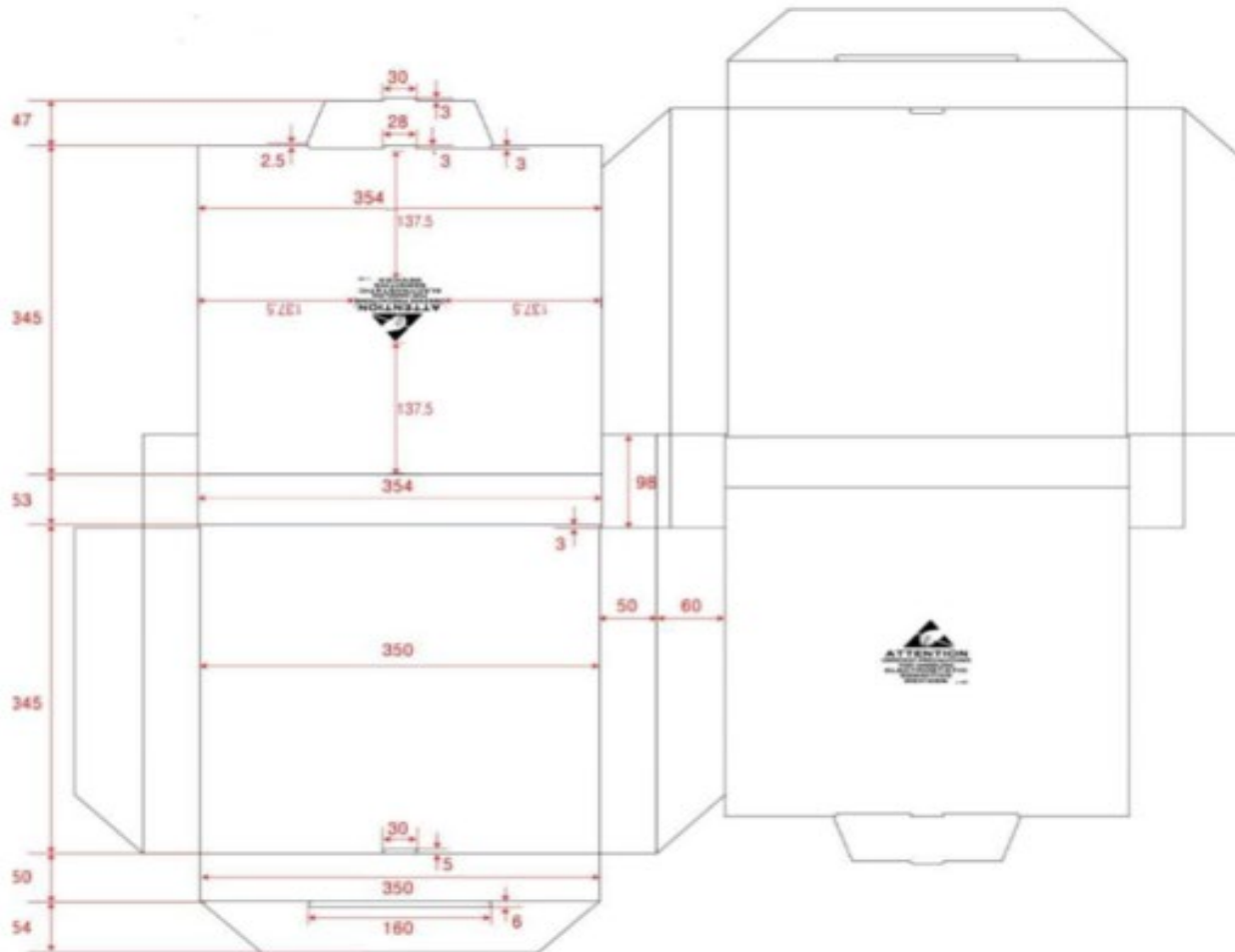

(4) Packing Drawing

■ Tray Drawing of TSOP II 44 – (1 of 2)

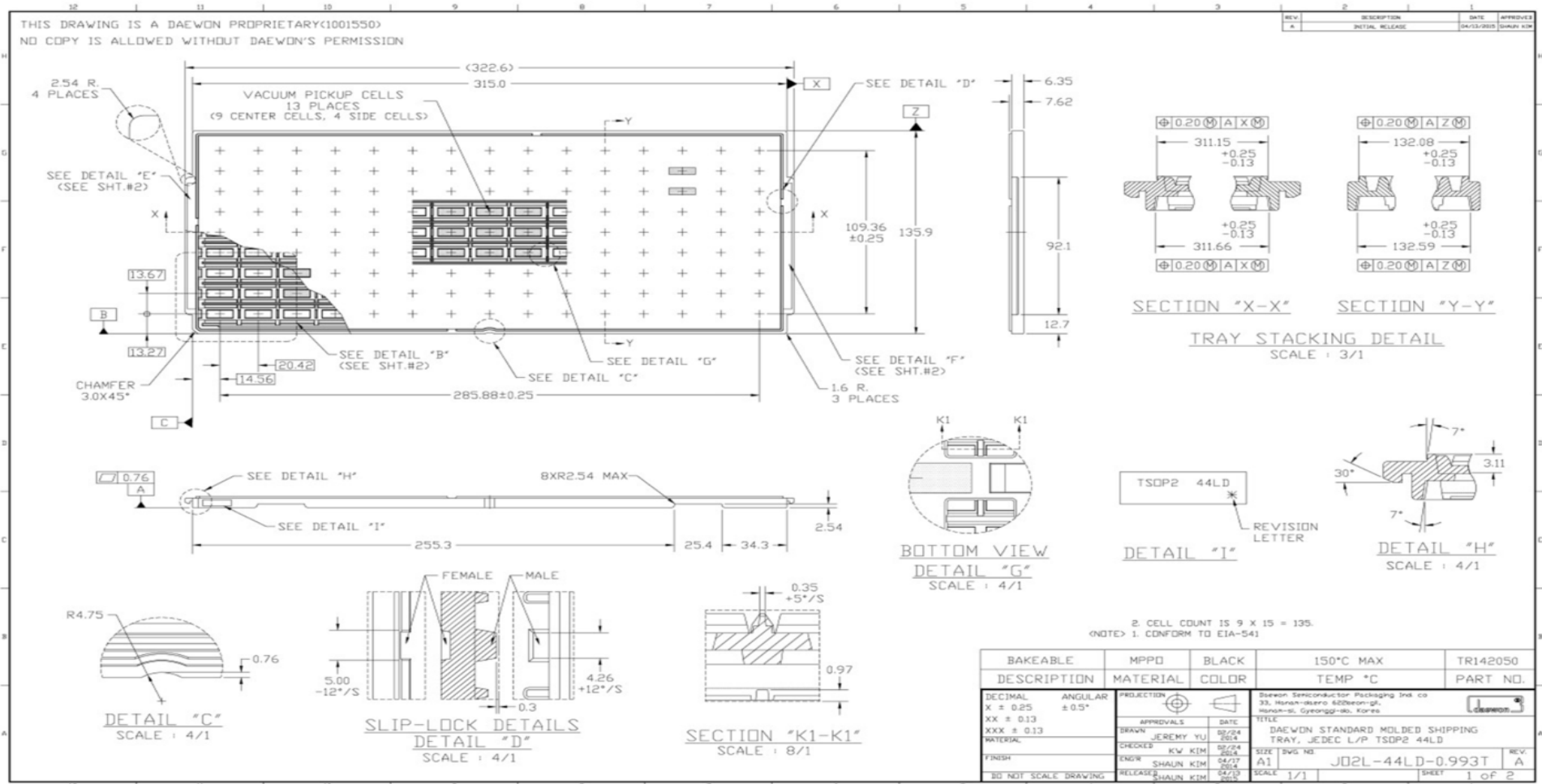

(4) Packing Drawing

■ Tray Drawing of TSOP II 44 – (2 of 2)

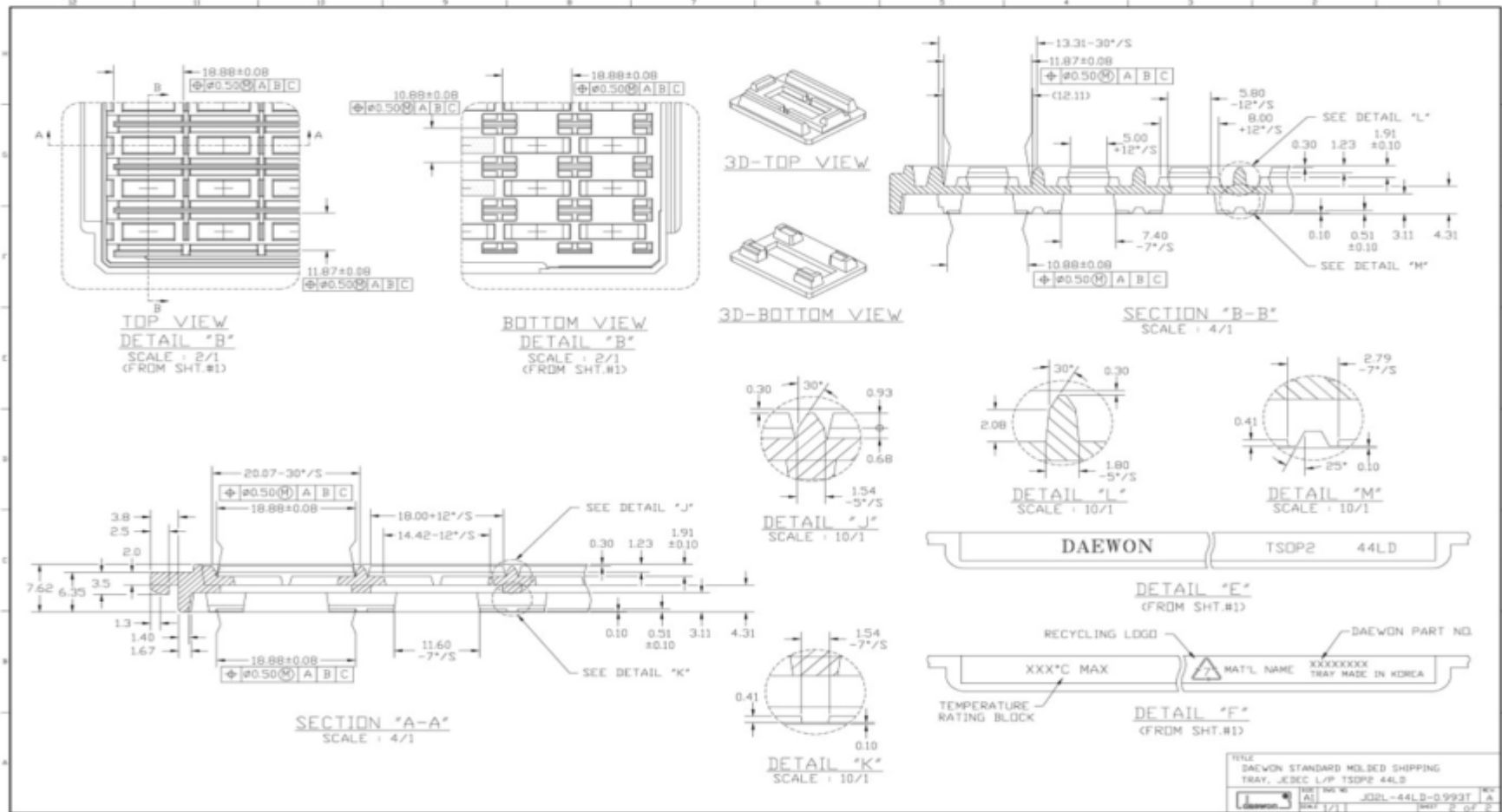

(4) Packing Drawing

Lock Reel Drawing of 44L-TSOPII

